

TOOLING SYSTEMS

QUICKLOCK

THE GLOBAL INNOVATION

UNIQUE. FUTURE-ORIENTED.

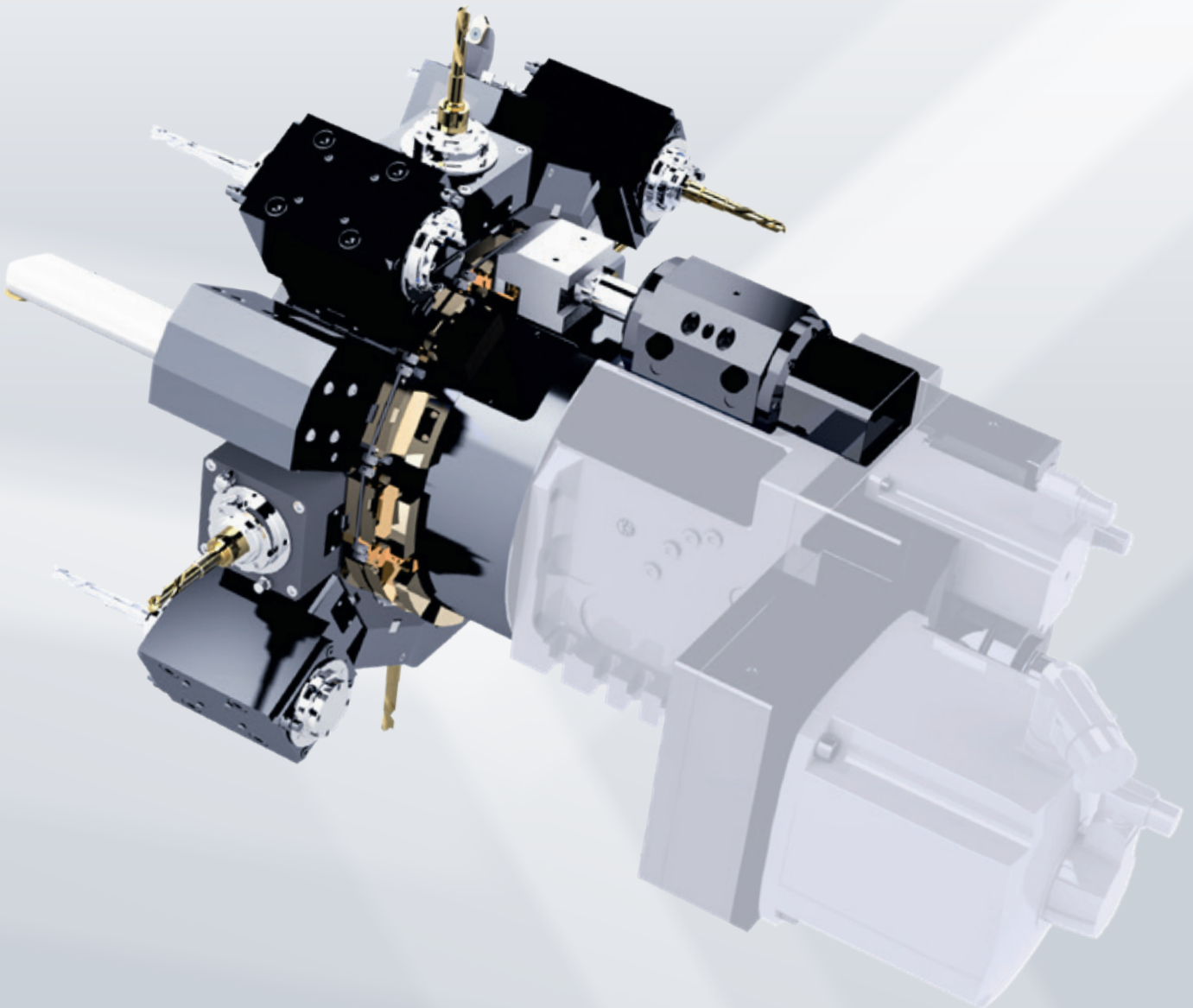

QUICKLOCK®

TOMORROW'S TOOL HOLDER CLAMPING SYSTEM

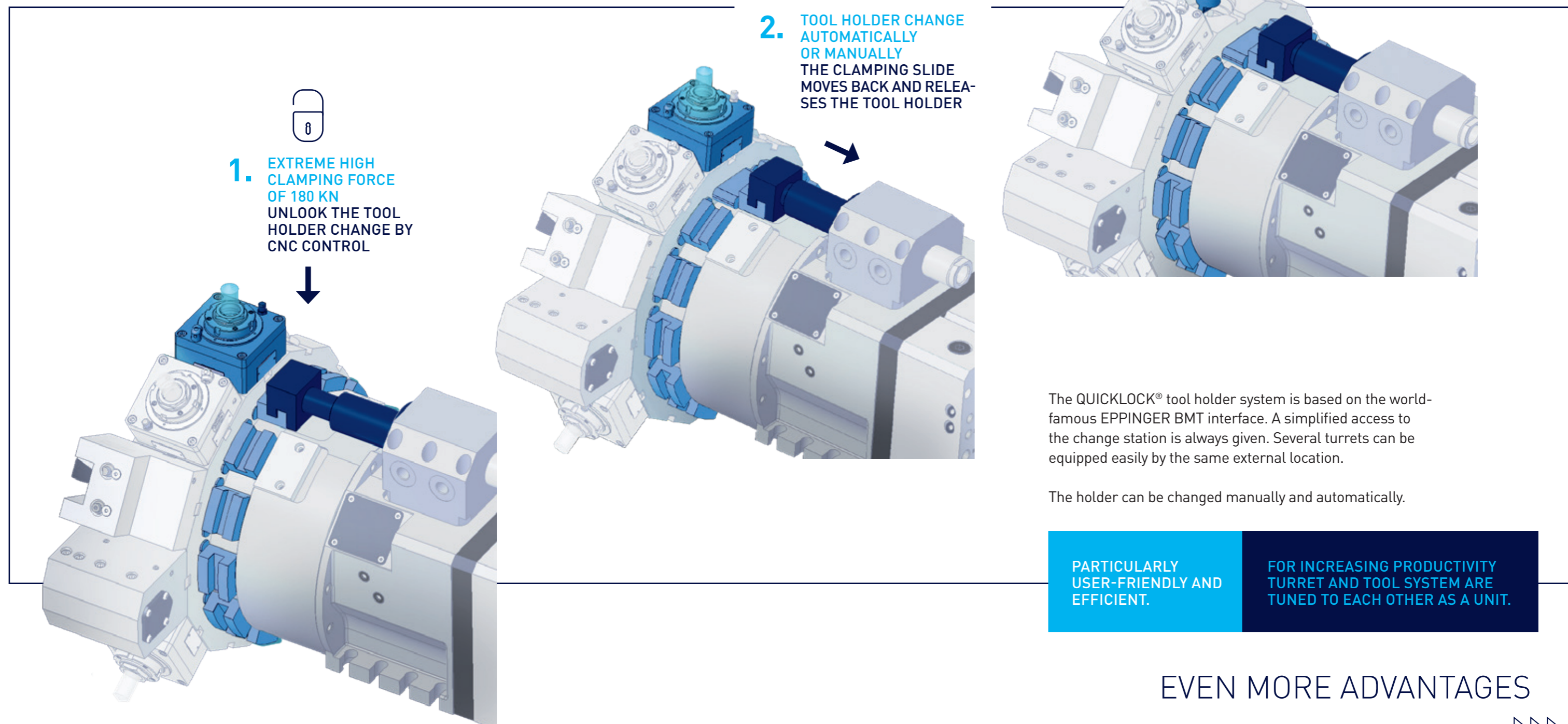

1. EXTREME HIGH CLAMPING FORCE OF 180 KN
UNLOCK THE TOOL HOLDER CHANGE BY CNC CONTROL

2. TOOL HOLDER CHANGE AUTOMATICALLY OR MANUALLY
THE CLAMPING SLIDE MOVES BACK AND RELEASES THE TOOL HOLDER

3. TOOL HOLDER CHANGE IN LESS THAN 10 SEC.
TOOL HOLDER CAN BE REMOVED

The QUICKLOCK® tool holder system is based on the world-famous EPPINGER BMT interface. A simplified access to the change station is always given. Several turrets can be equipped easily by the same external location.

The holder can be changed manually and automatically.

PARTICULARLY USER-FRIENDLY AND EFFICIENT.

FOR INCREASING PRODUCTIVITY TURRET AND TOOL SYSTEM ARE TUNED TO EACH OTHER AS A UNIT.

EVEN MORE ADVANTAGES



QUICKLOCK CONVINCING ADVANTAGES



FIND OUT MORE ABOUT
THE GLOBAL INNOVATION
QUICKLOCK.

OUR SALES DEPARTMENT
WILL GLADLY ADVISE YOU
UNDER +49 711 934 934-0

YOUR BENEFIT

- High exchange / clamping security. No external components needed, **the system is operator-independent.**
- **Reduced change errors.** The holder is always replaced at the same turret position.
- The lock position is monitored by the machine control. **No malfunction possible.**
- **High availability** due to a simple, safe clamping mechanism.
- **Self-locking system.** Insensitive against (cutting) vibrations during machining.
- **Tool holder application design independent** because tool holder clamping vice inside the disc.
- **For all tool holder** version suitable.
- **Only one tool holder magazine** needed for automatic change.
- **Extreme safe and quick tool holder change** – lock-/unlock cycle tested 10,000 times.
- **Increased process reliability** in combination with Industry 4.0.