

Servo High-End Planetary Gearbox PT - Series

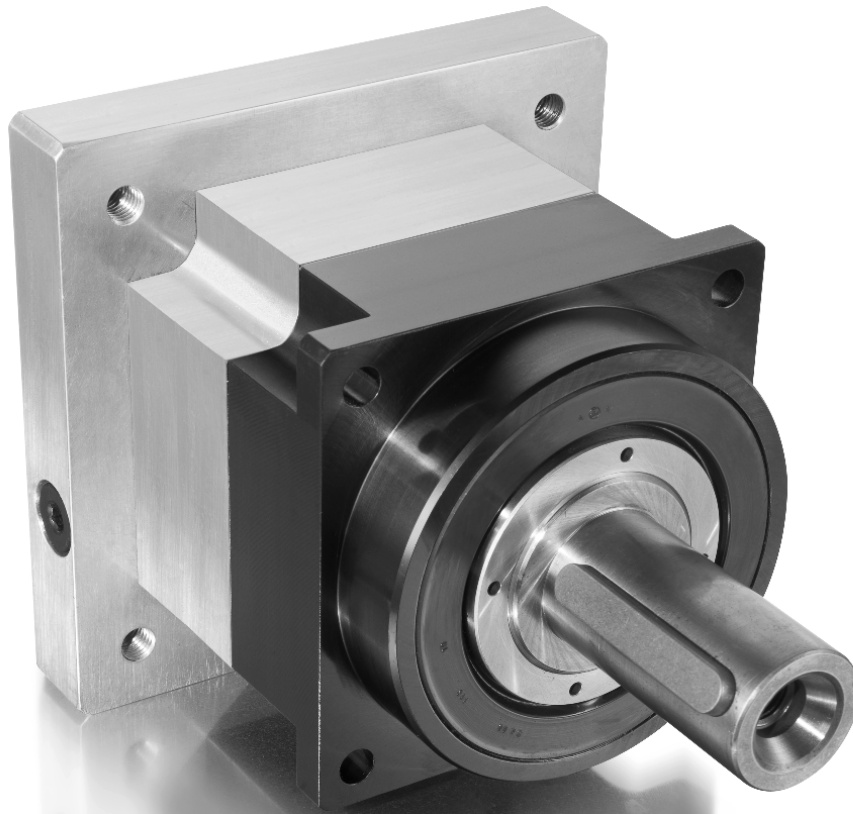

Zykloidgetriebe
Cycloid Gearboxes



Planetengetriebe
Planetary Gearboxes



Kegelrad-Planetengetriebe
Bevel Planetary Gearboxes



Kegelradgetriebe
Bevel Gearboxes

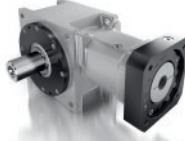

Hypoidgetriebe
Hypoid Gearboxes

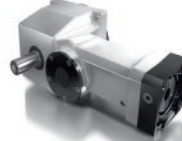

Hypoid-Stirnradgetriebe
Hypoid Helical Gearboxes



Getriebemotoren
Gear Motors



Verzahnungsentwicklung
Gear Development

EPPINGER Planetary Gearboxes

The servo gearboxes PT complete the whole range of our servo gearboxes that consist of high-end planetary gearboxes, right angle gearboxes, hypoid gearboxes, cycloid gearboxes as well as various combinations thereof. All common servo motors can be easily installed with all sizes of our gearboxes.

Our PT servo planetary gearboxes guarantee high stiffness and reliable transmission through their unique design. All ring gears, planet gears and sun pinions are case - hardened and ground. This provides for an outstanding transmission quality and allows for precise positioning tasks.

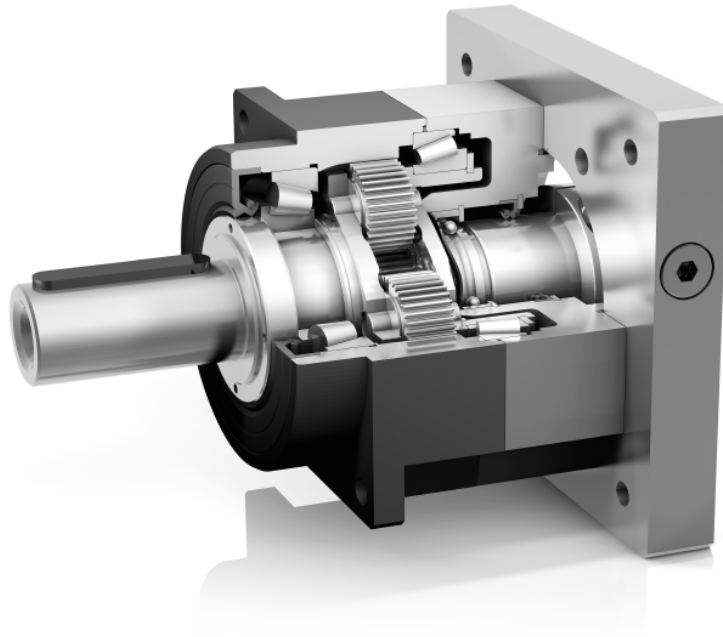

FEATURES AND BENEFITS OF PT PLANETARY GEARBOX SERIES

- Case - hardened and ground ring gears with minimized run - out
- Case - hardened and ground planet gears and sun pinions
- High transmission quality through high-precision components
- High positioning accuracy
- High torsional stiffness
- Solid bearings
- Compact design
- High permissible axial and radial loads
- Extremely high torsional stiffness due to the use of large taper roller bearings
- Suitable for all mounting positions
- Protection class IP 64
- High permissible emergency off-torque through form-locking power transmission.
- Smooth running through optimized gear geometry
- Reduced friction due to minimized sealing diameters
- Backlash-free power transmission by force-locking motor clutch

Our product range includes **bevel-, hypoid-, planetary-, cycloid-, special customized gearboxes and high precision gear technology**. The **compact mono-bloc design** makes our solutions **unique**.

Performance data

	Abbreviation	Unit	Ratio	PT062	PT076	PT101	PT141	PT182	PT242	Number of stages
Rated output torque [at nominal input speed, continuous duty loading-S1 and ambient temperature of 30°C]	T _{2N}	Nm	i = 3 : 1	-	-	145	330	860	2150	1
			i = 4 : 1	30	100	200	500	1200	3000	
			i = 5 : 1	30	120	240	600	1450	3600	
			i = 7 : 1	30	100	200	500	1200	3000	
			i = 10 : 1	24	72	145	330	860	2150	2
			i = 20/35/40/70 : 1	30	120	200	500	1200	3000	
i = 25/50 : 1	30	120	240	600	1450	3600				
i = 100 : 1	24	72	145	330	860	2150				
Max. acceleration torque [allowable for max. 1000 cycles per hr with overall running time less than 5% and at impulse time within 0.3 sec]	T _{2B}	Nm	i = 3 : 1	-	-	220	560	1440	3000	1
			i = 4 : 1	50	170	340	840	2040	5000	
			i = 5 : 1	50	200	400	1000	2400	6000	
			i = 7 : 1	50	170	340	840	2040	5000	
			i = 10 : 1	40	110	220	560	1440	3000	2
			i = 20/35/40/70 : 1	50	170	340	840	2040	5000	
i = 25/50 : 1	50	200	400	1000	2400	6000				
i = 100 : 1	40	110	220	560	1440	3000				
Emergency stop torque [allowable for 1000 times in service life]	T _{2Not}	Nm	i = 3 : 1	-	-	400	840	2160	5400	1
			i = 4 : 1	100	280	560	1260	3060	7500	
			i = 5 : 1	100	330	660	1500	3600	9000	
			i = 7 : 1	80	280	560	1260	3060	7500	
			i = 10 : 1	80	200	400	840	2160	5400	2
			i = 20/35/40/70 : 1	100	280	560	1260	3060	7500	
i = 25/50 : 1	100	330	660	1500	3600	9000				
i = 100 : 1	80	200	400	840	2160	5400				
Maximum input speed	n _{1max}	rpm	i = 3 : 1	-	-	4000	3200	2500	2000	1
			i = 4 : 1	5000	5000	4000	3200	2500	2000	
			i = 5 : 1	6300	6300	5000	4000	3200	2500	
			i = 7 : 1	8000	8000	6300	5000	4000	3000	
			i = 10 : 1	10000	10000	8000	6300	5000	3500	2
			i = 20/25/35 : 1	6300	6300	5000	4000	3200	3200	
i = 40 to 100 : 1	10000	10000	8000	6300	5000	5000				
Rated input speed	n _{1N}	rpm	i = 3 : 1	-	-	2300	1800	1300	800	1
			i = 4 : 1	3000	3000	2500	2000	1500	1000	
			i = 5 : 1	4000	4000	3000	2500	2000	1200	
			i = 7 : 1	5000	5000	4000	3000	2500	1500	
			i = 10 : 1	6000	6000	5000	4000	3000	2000	2
			i = 20/25/35 : 1	4000	4000	3000	2500	2000	2000	
i = 40 to 100 : 1	6000	6000	5000	4000	3000	3000				
Torsional backlash - standard		arcmin	all ratios	≤ 6	≤ 6	≤ 4	≤ 4	≤ 4	≤ 4	1
		arcmin		≤ 8	≤ 8	≤ 6	≤ 6	≤ 6	≤ 6	2
Torsional backlash - precision		arcmin		≤ 3	≤ 3	≤ 2	≤ 2	≤ 2	≤ 2	1
		arcmin		≤ 6	≤ 6	≤ 4	≤ 4	≤ 4	≤ 4	2
Torsional backlash - minimized		arcmin					≤ 1	≤ 1	≤ 1	1
		arcmin					≤ 1	≤ 1	≤ 1	2
Max. permissible radial load (on output shaft middle for 15000 hrs bearing life and with output shaft speed of n ₂ = 300 rpm)	F _{Rmax}	N		3000	4000	7200	10000	17500	23700	all stages
Max. permissible axial load	F _{Amax}	N		3400	4950	7600	10500	18500	24700	
Efficiency at full load	η	%				97%				1
		%				94%				2
Operating noise (on idle running with 3000 rpm input speed and i=10)	L _{pa}	dB(A)	≤ 53	≤ 56	≤ 56	≤ 56	≤ 65	≤ 65	1	
		dB(A)	≤ 49	≤ 51	≤ 55	≤ 55	≤ 63	≤ 63	2	
Weight	m	kg			on request				all stages	
Service life	L _h	h			> 20000					
Lubrication					oil filled					
Minimum operating temperature		°C			-10					
Maximum operating temperature		°C			90					
Degree of protection					IP 65					
Mounting position					any					
Motor Flange					optional					

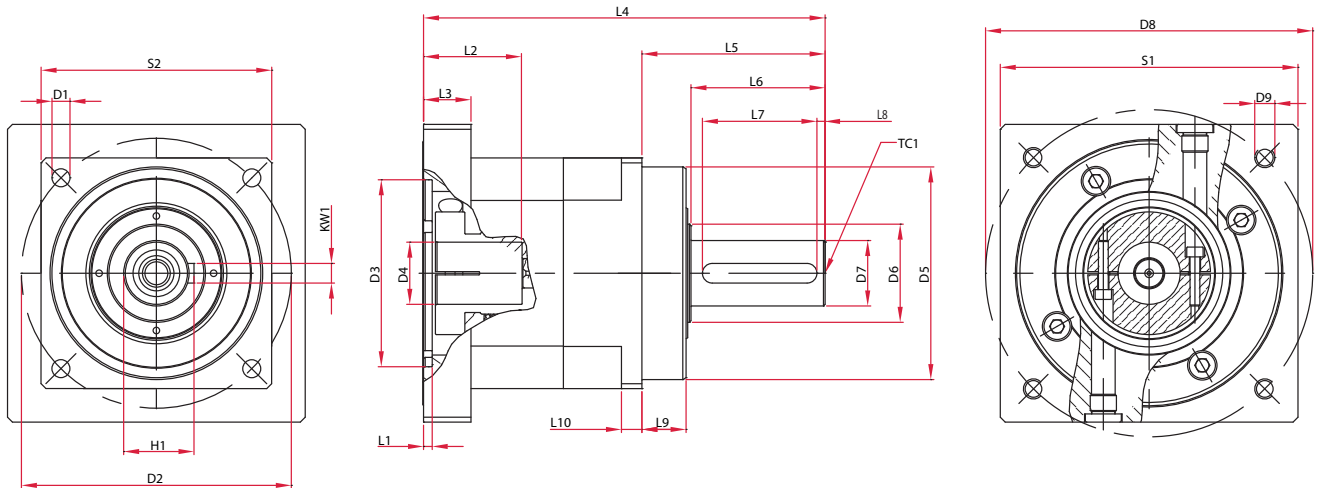

Dimensions (in mm)

	PT062	PT076	PT101	PT141	PT182	PT242	Stages
D1 Mounting hole - output side	5,5	6,6	9	11	13	17	all ratios
D2 Pitch circle diameter - output side	68	85	120	165	215	290	
D3 Centering diameter - drive side	to suit motor						1
D4 Bore diameter - drive shaft	max. F6						
	14	24	32	38	48	60	2
D5 Centering diameter - output side	g6						all ratios
D6 Shaft shoulder diameter - output shaft	20	28	40	60	65	95	
D7 Shaft diameter - output shaft	k6						
D8 Pitch circle diameter - drive side	to suit motor						
D9 Mounting thread - drive side	to suit motor						all ratios
H1 Key height - output shaft	18	24,5	35	43	55	90	
KW1 Key width - output shaft	5	6	10	12	16	22	
L1 Depth of centering bore - drive side	3,5	4,5	5,5	5,3	8	8	
L2 Maximum Bore depth - drive side	30	40	50	60	82	110	1
L3 Flange length - drive side	to suit motor shaft length						
L4 Overall length *	148	169	230	246	330	435	2
L5 Shaft length from housing face - output side	48	56	88	112	112	170	all ratios
L6 Shaft length - output side	28	36	58	82	82	130	
L7 Key length - output shaft	22	28	50	70	70	110	
L8 Key position from shaft end - output side	3	4	4	5	5	7,5	
L9 Spigot length - output side	18	18	28	27	27	37	
L10 Flange length - output side	8	8	10	12,5	22	30	
S1 Flange size - drive side	to suit motor						all ratios
S2 Flange size - output side	62	80	101	141	182	242	
TC1 Centre hole to DIN332 - output side	M5x12	M8x19	M12x28	M16x36	M20x42	M20x42	

* - value indicated is with L2 given above and overall length depends on motor shaft length

Subject to change in design. We recommend technical clarification prior to ordering.



EPPINGER
PRECISION GEAR SOLUTIONS