

# BM – spiral bevel gear boxes

Solid and Hollow Shaft Design

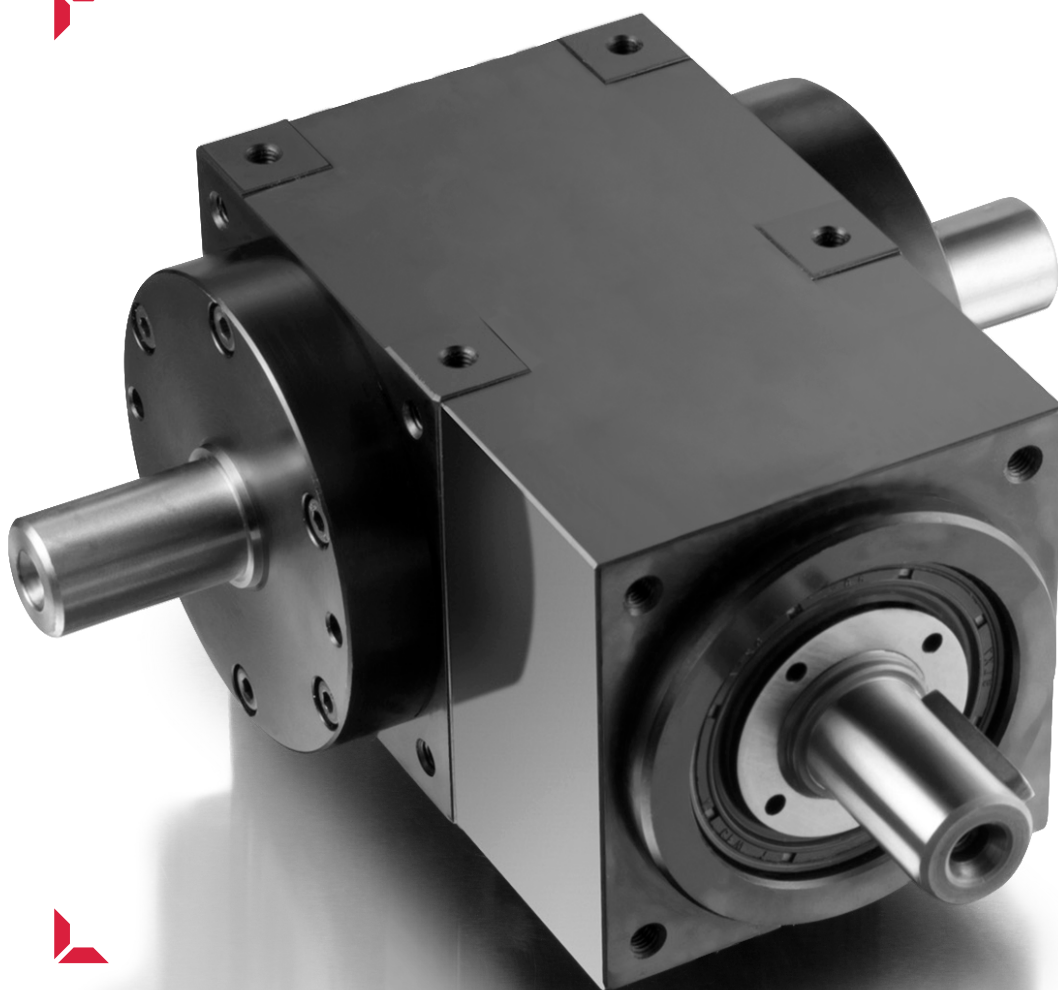

Zykloidgetriebe  
Cycloid Gearboxes



Planetengetriebe  
Planetary Gearboxes



Kegelrad-Planetengetriebe  
Bevel Planetary Gearboxes



Kegelradgetriebe  
Bevel Gearboxes

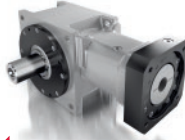

Hypoidgetriebe  
Hypoid Gearboxes

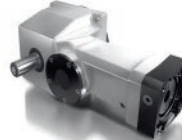

Hypoid-Stirnradgetriebe  
Hypoid Helical Gearboxes



Getriebemotoren  
Gear Motors



Verzahnungsentwicklung  
Gear Development

# EPPINGER BM bevel gear boxes

The BM series of bevel gear boxes is predestined for all gear box applications which require compact dimensions and maximum torque transfer at best efficiency rates. Precision of the axes and bearing

seats, combined with Gleason bevel gears to take high loads, are the basis for minimized tooth clearance and optimal transmission properties. Presently the gear boxes are available in 5 sizes, each with a ratio of  $i = 1 : 1$ .

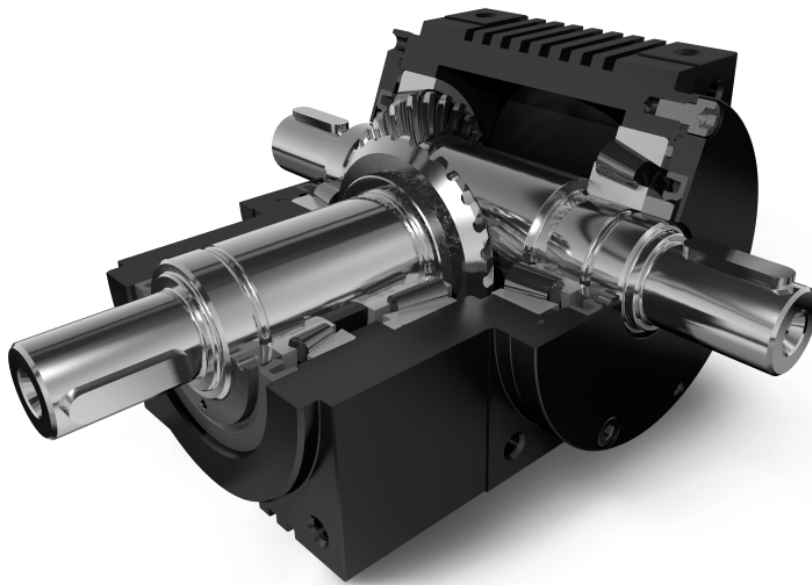

## FEATURES AND BENEFITS OF THE NEW BM BEVEL GEAR BOX SERIES

### THE HOUSING:

- single-component housing with maximum precision of axes and bearing seats, all integrated directly into the housing
- high power density of the gear boxes through compact housing dimensions
- drive-sided gear box interface offers the option of direct connection of planetary gear box pre-stages, as well as secure mounting of motor flanges
- mounting threads on all sides of the housing allow for stable attachment of the gear box in various installation positions

### THE GEARS:

- heavy duty bevel gears, designed and manufactured according to the Gleason process, result in optimal gearing efficiency, high transmission precision and reduced stress on the bearings
- friction-locked, zero backlash connection of the crown gears on the drive shaft reduces the mass of the gearing component and centers zero backlash connection

- precise gear setting by measuring the gear box components and 100% running test of the gear boxes in assembly

### SHAFTS AND BEARINGS:

- steel alloy shafts with precise bearing seats as basis for precise and heavy duty taper roller bearings
- extremely precise positioning and setting of bearings through the use of ground steel shims and splinting of the inner rings

### THE RANGE OF GEAR BOXES:

- presently 5 gear box sizes with a ratio of  $i = 1 : 1$
- gear box can be supplied with solid or hollow shafts in standard and customized designs
- best efficiency when high transmission performance is required. High efficiency levels of course result in a reduction of energy costs.

## Performance data

	Abbreviation	Unit	Ratio	BM075	BM090	BM110	BM140	BM170	BM210	BM240	BM280
Rated output torque	$T_{2N}$	Nm	$i = 1 : 1$	80	130	300	570	1050	In process of planning		
Emergency stop torque <sup>1</sup>	$T_{2Not}$	Nm		160	260	600	1140	2100			
Rated input speed	$n_{1N}$	rpm	$i = 1 : 1$	1800	1500	1100	900	850			
Max. input speed <sup>2</sup>	$n_{1max}$	rpm		3000	2500	2000	2000	1500			
Max. permissible radial load <sup>3,4</sup>	$F_{R1max}$	N		1500	2000	3500	5500	7800			
	$F_{R2max}$	N		2000	2700	4500	7200	11000			
Max. permissible axial load <sup>4</sup>	$F_{A1max}$	N		800	1000	1800	2800	4000			
	$F_{A2max}$	N		1000	1400	2300	3800	5500			
Torsional backlash output shaft		arcmin	standard reduced	$\leq 13$ $\leq 8$	$\leq 12$ $\leq 7$	$\leq 11$ $\leq 7$	$\leq 10$ $\leq 6$	$\leq 10$ $\leq 6$			
Efficiency at rated load	$\eta$	%		$> 98$							
Operating noise <sup>5</sup>	$L_{pa}$	db(A)		70	73	75	76	77			
Service life	$L_h$	h		$> 15.000$							
Oil filling <sup>6</sup>		ltr		0.06	0.09	0.16	0.35	0.80			
Lubrication				Synthetic oil, ISO VG 150 (up to size 140 incl.)							
Operating temperature		°C		$-20$ to $90$							
Weight <sup>7</sup>		kg		5.5	8.9	15.7	31.1	48.0			
As-delivered condition				Housing and flanges burnished black							
Mass moment of inertia <sup>8</sup>	$I_1$	kgcm <sup>2</sup>		Upon request							

<sup>1</sup> 1000 x permissible short overload peaks during service life of gear boxes

<sup>2</sup> requires special measures

<sup>3</sup> referred to center of shaft journal

<sup>4</sup> reduced values for nominal torque/nominal speed

<sup>5</sup> for nominal speed and partial load

<sup>6</sup> dependent on installation position

<sup>7</sup> with output shaft design S13

<sup>8</sup> referred to the input shaft

## Thermal limit rating

	Abbreviation	Unit	BM075	BM090	BM110	BM140	BM170	BM210	BM240	BM280	
Thermal limit rating <sup>9</sup>	$P_{therm}$	kW	5.0	7.5	11.0	18.0	26.5				
Definition: the thermal limit rating $P_{therm}$ is the transferable output during continuous operation at a max. permissible oil bath temperature of 90 °C. The permissible limit values for the thermal limit rating for intermittent operation can be determined as reference values as a function of rotational speed $n_1$ and ambient temperature by applying the correction factors given below. In this context the effective output must not exceed the permissible limit values.  $P_{therm, effective} < P_{therm, permissible}$			<b>Drive speed [rpm]</b> <b>Correction factor K1</b>		0.4*n1N	0.7*n1N	n1N				
					1.0	0.8	0.5				
<b>Example:</b>			<b>Gear box</b>	<b>Revolution speed</b>	<b>ED</b>	<b>Ambient</b>					
<b>Permissible thermal limit rating at:</b>			BM140 1 : 1	560 rpm	80%	40°C					
$P_{therm, permissible} = P_{therm} (BM140) \times K1 \times K2 \times K3 = 18.0 \text{ kW} \times 0.8 \times 1.2 \times 0.8 = 13.8 \text{ kW}$					<b>Ambient temperature [°C] correction factor K3</b>		10	20	30	40	50
							1.20	1.00	0.83	0.70	0.60

<sup>9</sup> at  $T_{2N}$ ,  $i = 1:1$ ,  $RT=20^\circ\text{C}$  and  $ED = 100\%$

# Solid Shaft Design

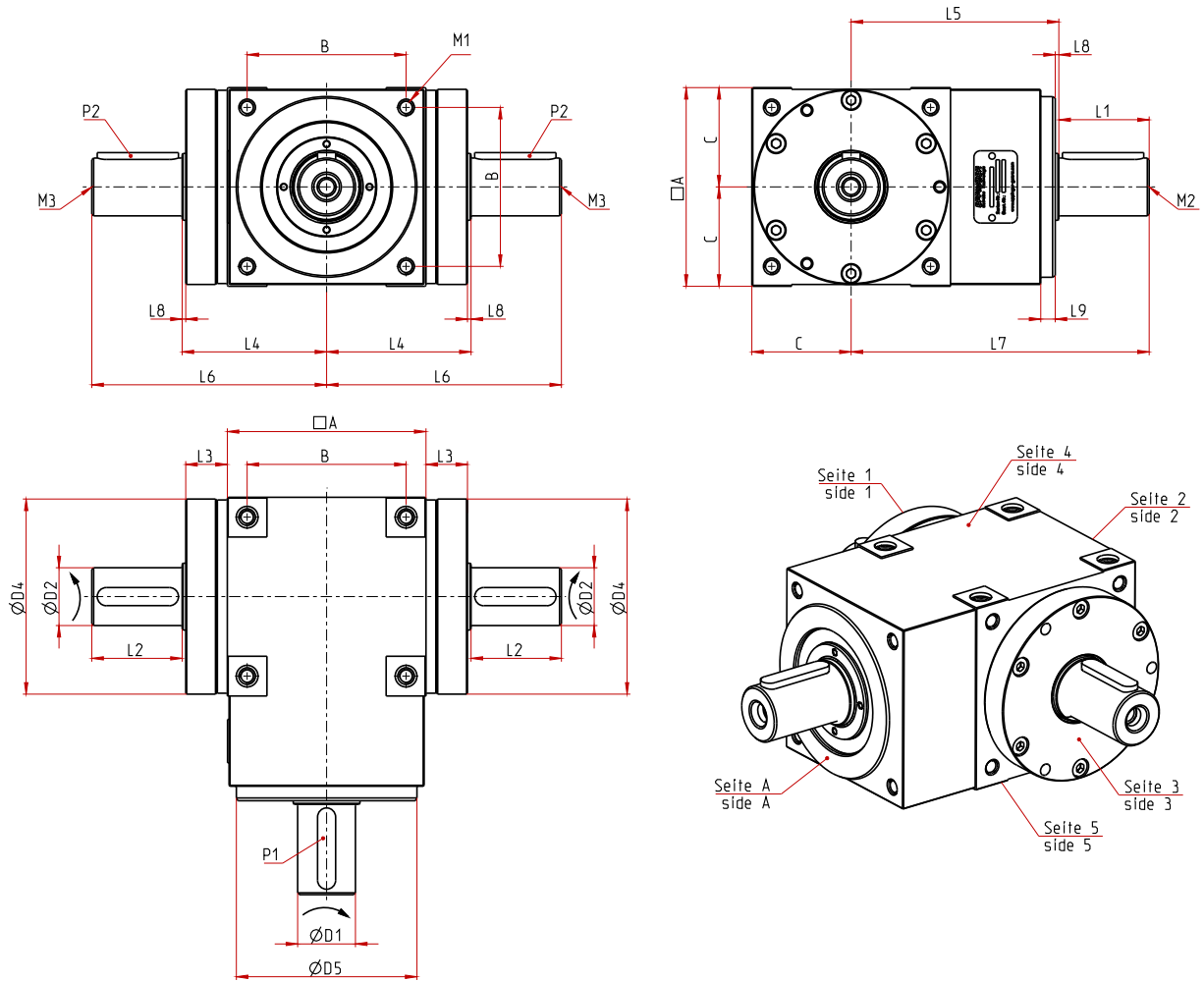

Solid Shaft Design (dimensions in mm)

	BM075	BM090	BM110	BM140	BM170	BM210	BM240	BM280
□ A	75	90	110	140	170	In process of planning		
B	60	72	88	110	134			
C	37.5	45	55	70	85			
Ø D1	20 k6	25 k6	32 k6	40 k6	50 k6			
Ø D2	20 k6	25 k6	32 k6	40 k6	50 k6			
Ø D4	73 h7	88 h7	108 h7	135 h7	165 h7			
Ø D5	67 g6	80 g6	100 g6	120 g6	128 g6			
L1	35	40	50	60	80			
L2	35	40	50	60	80			
L3	18.5	18	23	25	30			
L4	58	65	80	97	117			
L5	90	100	115	145	175			
L6	93	105	130	157	197			
L7	125	140	165	205	255			
L8	2	2	2	2	2			
L9	6	8	8	8	10			
P1	6x6x28	8x7x32	10x8x45	12x8x50	14x9x70			
P2	6x6x28	8x7x32	10x8x45	12x8x50	14x9x70			
M1	M5x10	M6x12	M8x16	M10x20	M12x24			
M2/M3*	M6	M8	M10	M16	M16			

\* Thread in shaft end acc. to form DS, DIN 332

# Hollow Shaft Design

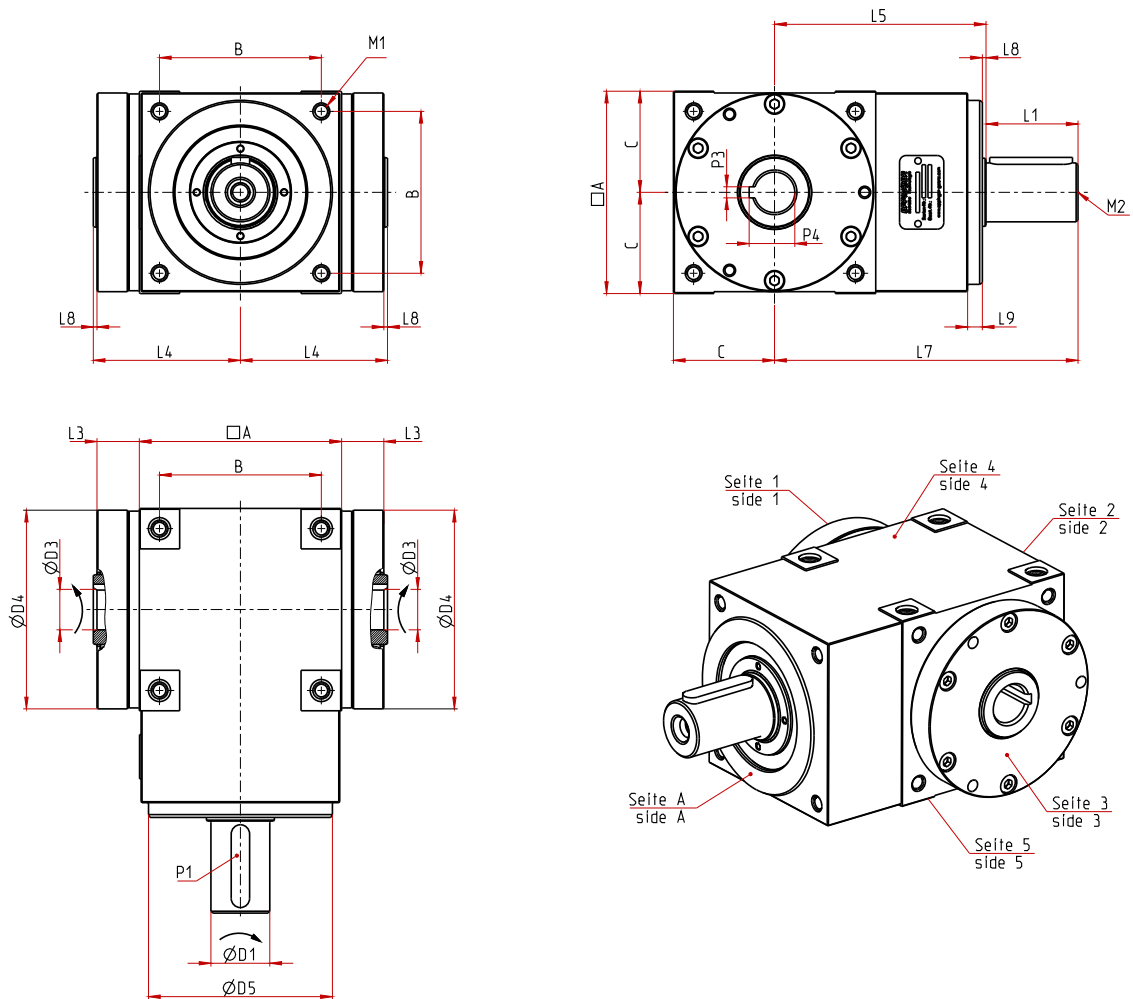

Hollow Shaft Design (dimensions in mm)

	BM075	BM090	BM110	BM140	BM170	BM210	BM240	BM280
□ A	75	90	110	140	170	In process of planning		
B	60	72	88	110	134			
C	37.5	45	55	70	85			
Ø D1	20 k6	25 k6	32 k6	40 k6	50 k6			
Ø D3	14 H7	18 H7	22 H7	32 H7	40 H7			
Ø D4	73 h7	88 h7	108 h7	135 h7	165 h7			
Ø D5	67 g6	80 g6	100 g6	120 g6	128 g6			
L1	35	40	50	60	80			
L3	18.5	18	23	25	30			
L4	58	65	80	97	117			
L5	90	100	115	145	175			
L7	125	140	165	205	255			
L8	2	2	2	2	2			
L9	6	8	8	8	10			
P1	6x6x28	8x7x32	10x8x45	12x8x50	14x9x70			
P3	5 JS9	6 JS9	6 JS9	10 JS9	12 JS9			
P4	16.3	20.8	24.8	35.3	43.3			
M1	M5x10	M6x12	M8x16	M10x20	M12x24			
M2*	M6	M8	M10	M16	M16			

\* Thread in shaft end acc. to form DS, DIN 332

# EPPINGER precision gear boxes at a glance

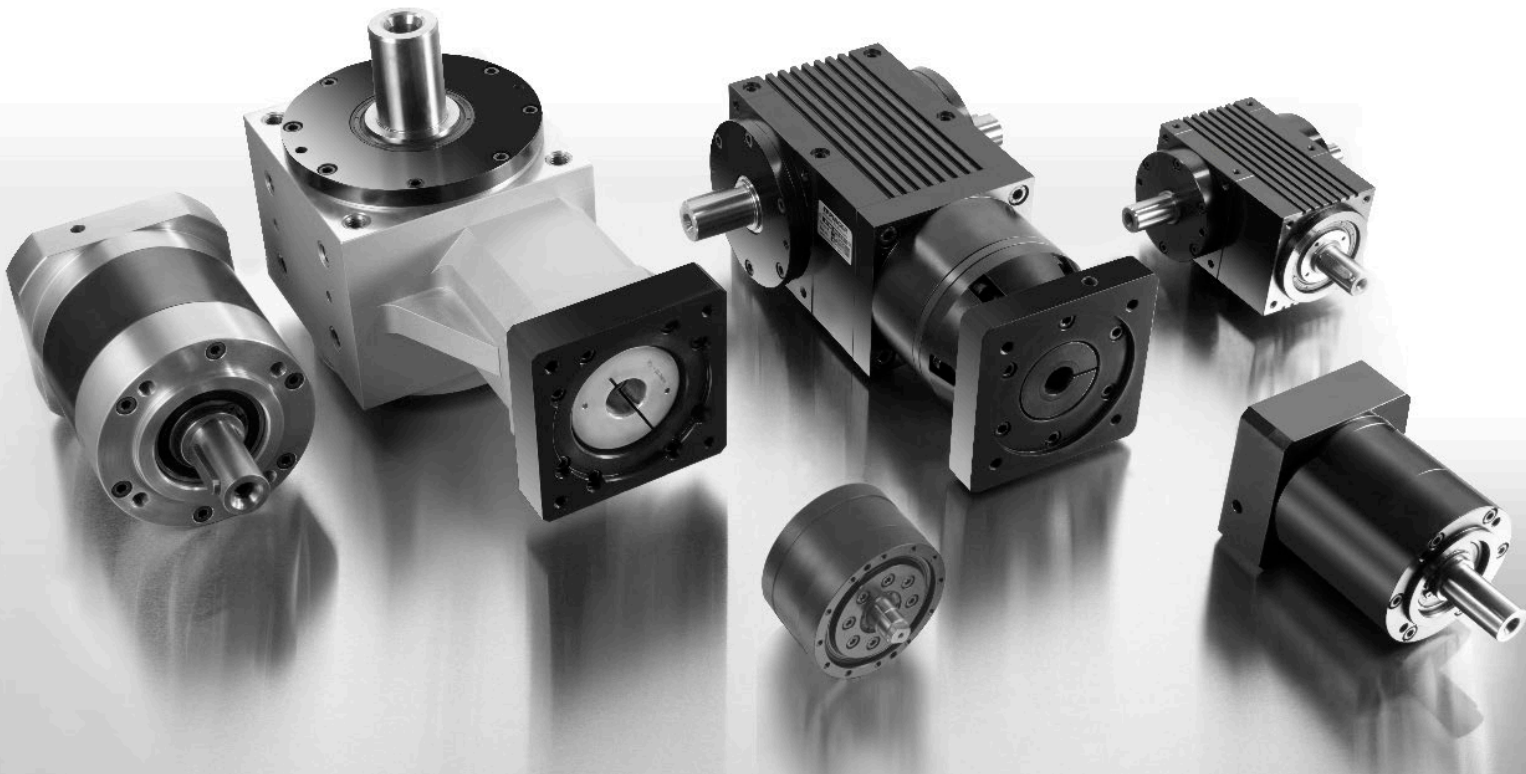

Our product range includes besides **bevel-, hypoid-, planetary- and cycloidal gear boxes** also **special customized gear boxes and high precision gear technology**. With our **gear motors and integrated combinations of our gear box series** we extended our portfolio.



**EPPINGER**   
PRECISION GEAR SOLUTIONS